



B-SERIES
SEWAGE & WASTEWATER PUMPS

DIMENSIONS

Bend model:
BEND100-100 ANSI

100B45.5 -64
100B47.5 -64

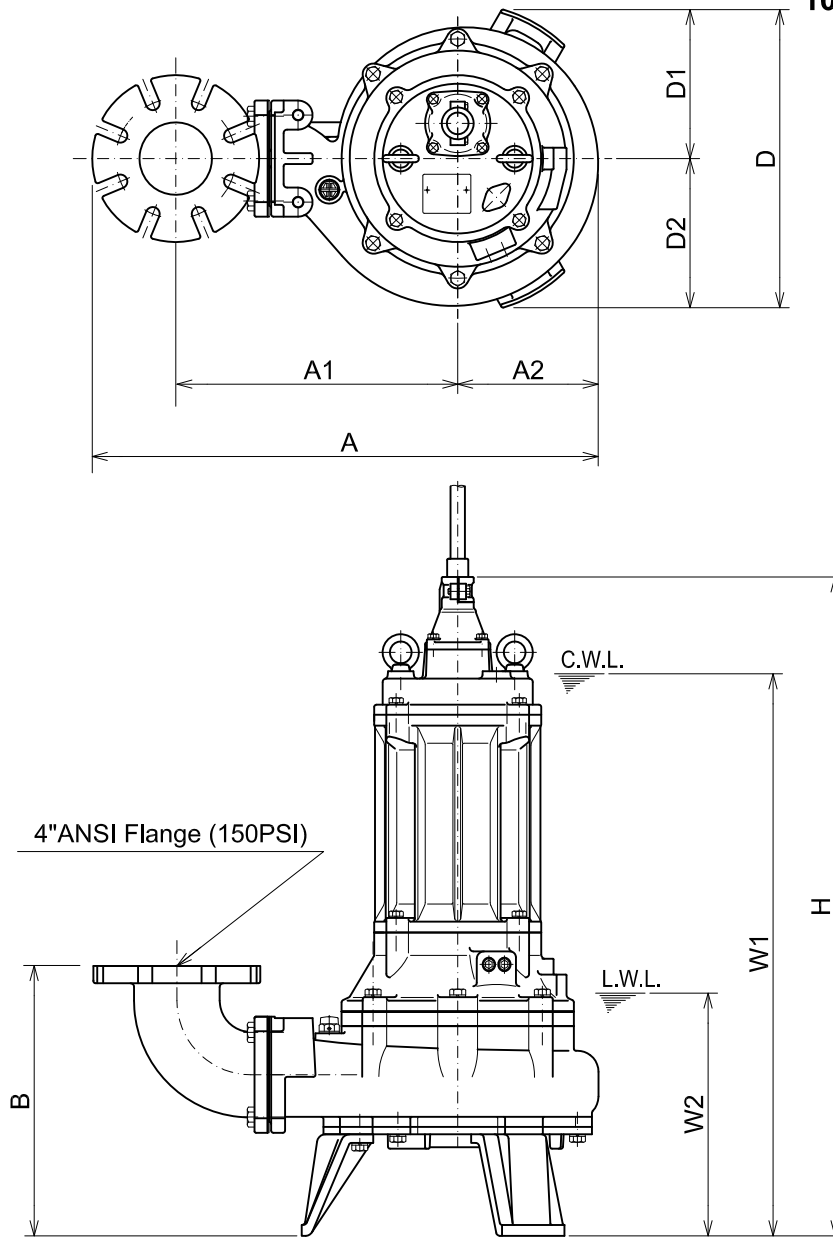

C.W.L. :Continuous running Water Level
L.W.L. :Lowest running Water Level

DIMENSIONS:USCS(Inch)

Model	HP	NOM. SIZE	Pump & Motor								C.W.L. W1	L.W.L. W2	*Wt. (lbs.)
			A	A1	A2	B	D	D1	D2	H			
100B45.5 -64	7.5	4"	27 13/16	15 5/8	7 5/8	14 5/8	16 1/8	8 1/16	8 1/16	35 3/4	30 1/2	13 1/4	313
100B47.5 -64	10	4"	27 13/16	15 5/8	7 5/8	14 5/8	16 1/8	8 1/16	8 1/16	36 9/16	31 1/2	13 1/4	362

*Excluding Cable.

DIMENSIONS:METRIC(mm)

Model	kW	NOM. SIZE	Pump & Motor								C.W.L. W1	L.W.L. W2	*Wt. (kg)
			A	A1	A2	B	D	D1	D2	H			
100B45.5 -64	5.5	100	706	397	194	372	410	205	205	908	775	335	142
100B47.5 -64	7.5	100	706	397	194	372	410	205	205	929	800	335	164



B-SERIES
SEWAGE & WASTEWATER PUMPS

DIMENSIONS

TOS100B45.5 -64
TOS100B47.5 -64

Guide Rail System
Model : TOS3-100-100 ANSI
Wt. : 108lb. (49kg)

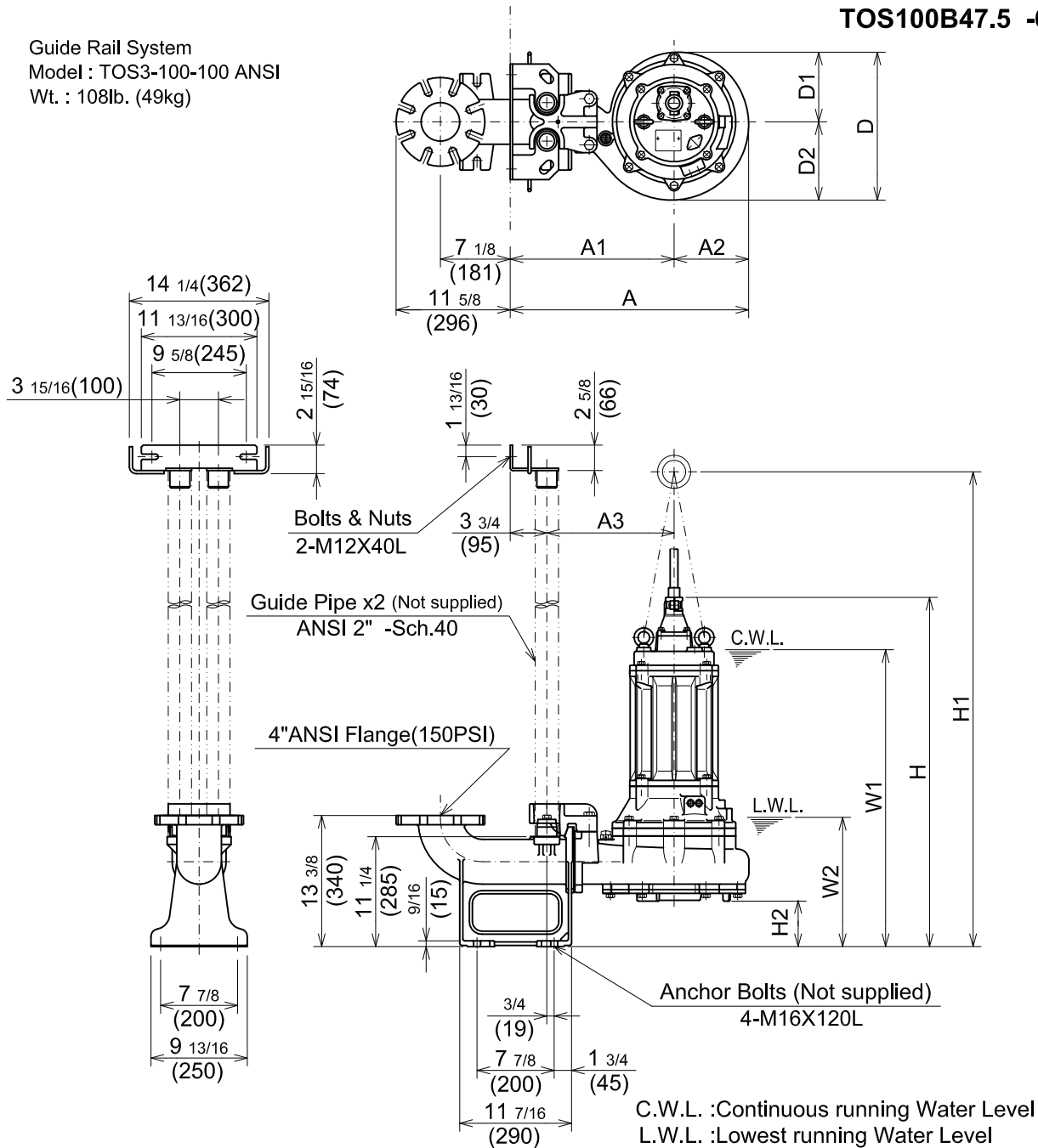

DIMENSIONS:USCS(Inch)

Model	HP	NOM. SIZE	Pump & Motor										C.W.L. W1	L.W.L. W2	*Wt. (lbs.)
			A	A1	A2	A3	D	D1	D2	H	H1	H2			
TOS100B45.5 -64	7.5	4"	24 3/8	16 3/4	7 5/8	13	15 1/8	7 1/8	8	35 11/16	48 3/4	4 5/8	30 1/2	13 1/4	309
TOS100B47.5 -64	10	4"	24 3/8	16 3/4	7 5/8	13	15 1/8	7 1/8	8	36 1/2	50 1/4	4 5/8	31 1/2	13 1/4	357

DIMENSIONS:METRIC(mm)

Model	kW	NOM. SIZE	Pump & Motor										C.W.L. W1	L.W.L. W2	*Wt. (kg)
			A	A1	A2	A3	D	D1	D2	H	H1	H2			
TOS100B45.5 -64	5.5	100	619	425	194	330	384	181	203	906	1238	118	775	335	140
TOS100B47.5 -64	7.5	100	619	425	194	330	384	181	203	927	1275	118	800	335	162

*Excluding TOS & Cable.



B-SERIES
SEWAGE & WASTEWATER PUMPS

PERFORMANCE
CURVE

MODEL	BORE	HP	KW	RPM	SOLIDS DIA.	LIQUID	SG.	VISCOSITY	TEMP.
(TOS)100B45.5 -64	4"/100mm	7.5	5.5	1731	1.57"/40mm	Water	1.0	1.123cSt.	60°F
PUMP TYPE	PHASE	VOLTAGE	AMPERAGE	HZ	STARTING METHOD	INS.CLASS			
Sewage&Wastewater	3	208-230/460/575	22.6-20.5 / 10.3 / 8.1	60	Direct On Line	F			
CURVE No.	DATE	PHASE	VOLTAGE	AMPERAGE	HZ	STARTING METHOD	INS.CLASS		
-	-	-	-	-	-	-	-		

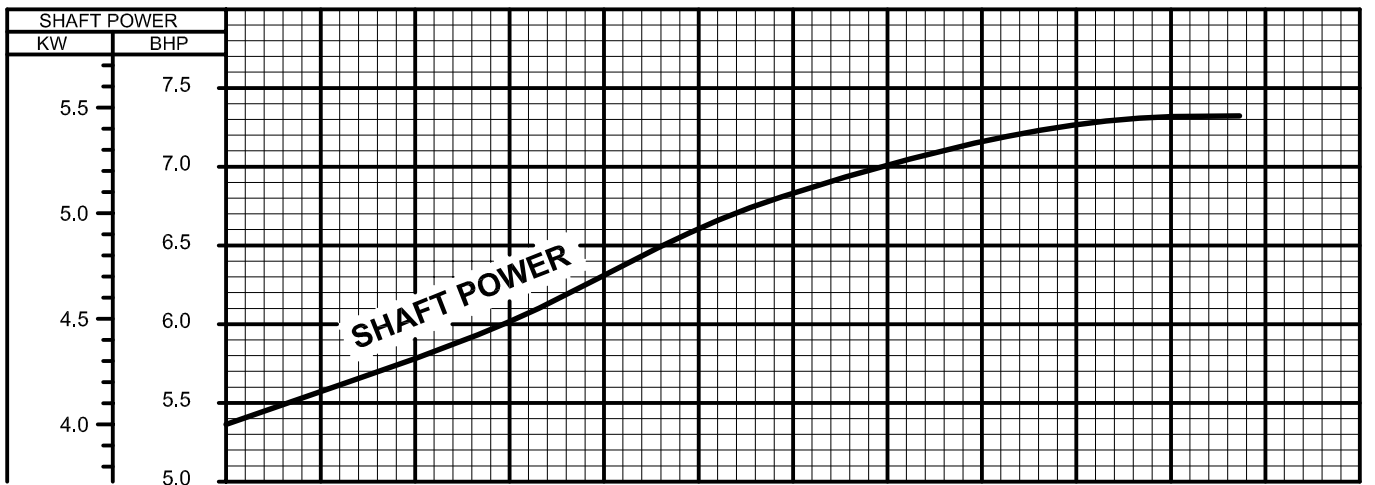
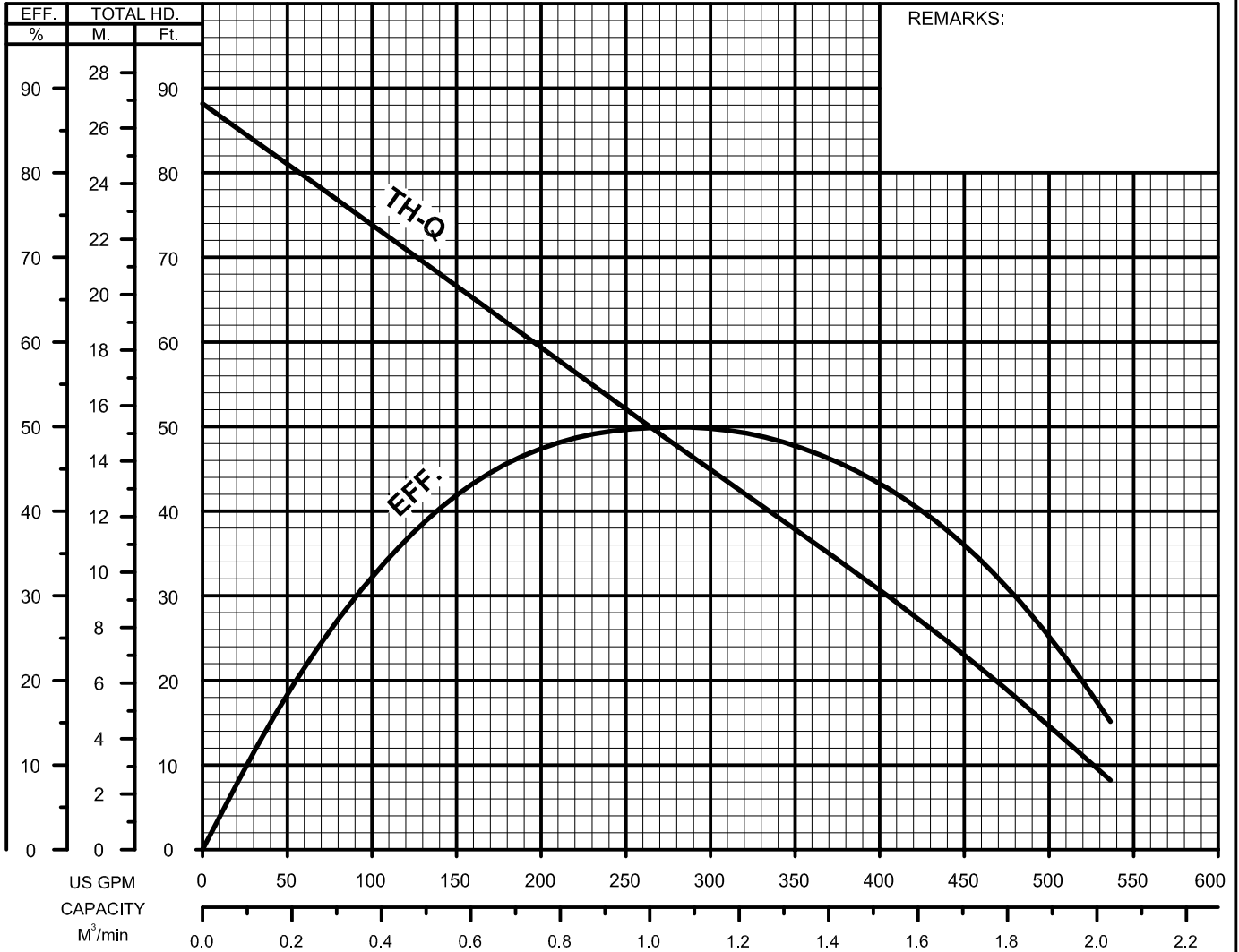



**B-SERIES
SEWAGE & WASTEWATER PUMPS**

SECTIONAL VIEW

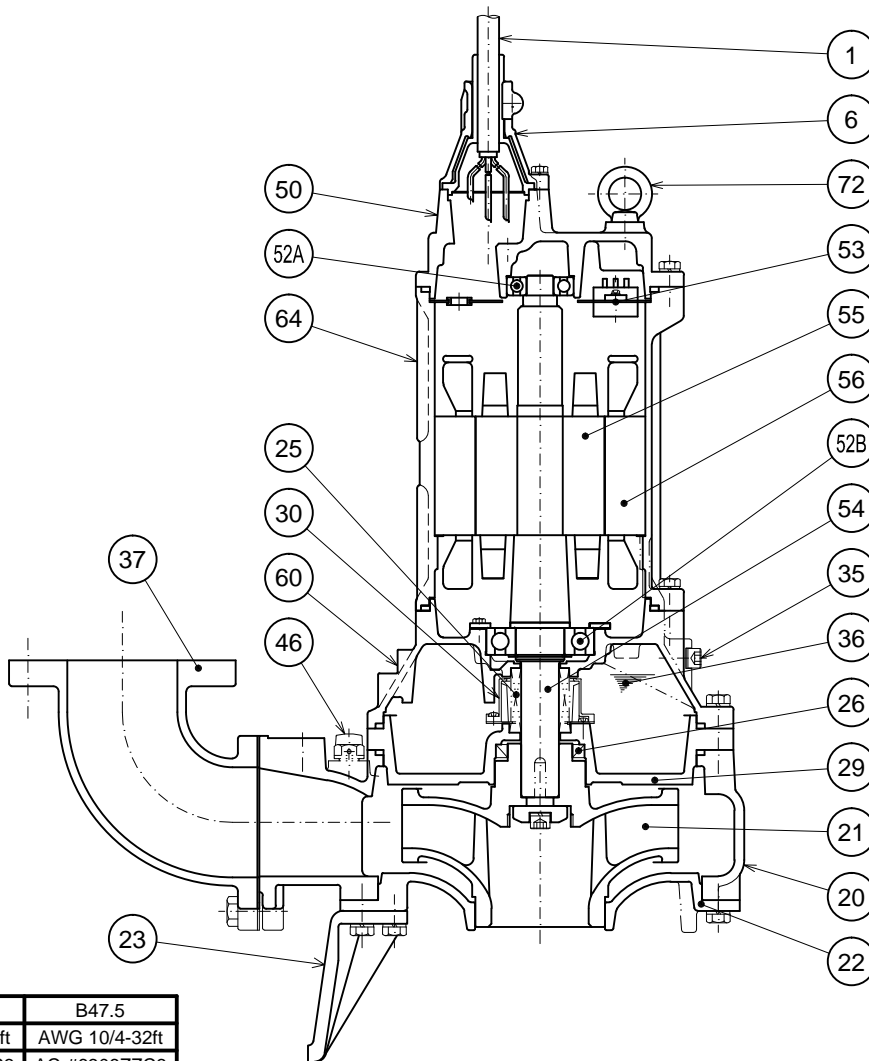

100B45.5 -64
100B47.5 -64

	B45.5	B47.5
* 1	AWG 12/4-32ft	AWG 10/4-32ft
* 2	AC-#6305ZC3	AC-#6306ZC3

PART#	DESCRIPTION	MAIN MATERIAL / NOTE	RELATED ASTM,AISI CODE	RELATED EN CODE	QTY
1	Power Cable	Chloroprene Sheath * 1			1
6	Stuffing Box	Cast Iron	A48M Class30B	EN 1561 GJL-200	1
20	Pump Casing	Cast Iron	A48M Class30B	EN 1561 GJL-200	1
21	Impeller	Cast Iron	A48M Class30B	EN 1561 GJL-200	1
22	Suction Cover	Cast Iron	A48M Class30B	EN 1561 GJL-200	1
23	Pump Stand	Cast Iron	A48M Class30B	EN 1561 GJL-200	3
25	Mechanical Seal	Silicon Carbide / H-35			1
26	Oil Seal	NBR / TC608212			1
29	Oil Casing	Cast Iron	A48M Class30B	EN 1561 GJL-200	1
30	Oil Lifter	PBT Resin W/GF40			1
35	Oil Plug	Stainless Steel	S 30400	1.4301	2
36	Lubricant	Turbine Oil ISO VG32 or SAE 10W-20			
37	Discharge Bend	Cast Iron / 4"ANSI Flange(150PSI)	A48M Class30B	EN 1561 GJL-200	1
46	Air Release Valve	Nylon			1
50	Motor Bracket	Cast Iron	A48M Class30B	EN 1561 GJL-200	1
52A	Upper Bearing	*2			1
52B	Lower Bearing	#6309ZC3			1
53	Motor Protector				1
54	Shaft	Stainless Steel	S 42000	1.4028	1
55	Rotor				1
56	Stator				1
60	Bearing Housing	Cast Iron	A48M Class30B	EN 1561 GJL-200	1
64	Motor Housing	Cast Iron	A48M Class30B	EN 1561 GJL-200	1
72	Lifting Lug Bolt	Steel	A283 Grade D	EN 10025 S275	2

PARTS LIST		SEWAGE & WASTEWATER PUMPS			10/24/2017	
ITEM	PART No.	DESCRIPTION	QTY	SIZE	MATERIAL	NOTES
1	001-936-23	Cabtyre Cable Set (32') 60HZ(USA)	1	2PNCT4Cx3.5mm2	KR-2	
2	140-055-10	Hex.Bolt	4	M8x25	SUS304	
3	142-163-18	Spring Washer	4	M8	SUS304	
4	070-107-18	Cable Clamp	1		FC	included in ITEM #1 Cable Ass'y
5	140-035-14	Hex.Bolt	2	M6x20	SUS304	included in ITEM #1 Cable Ass'y
6	006-126-14	Stuffing Box	1	No.2	FC	included in ITEM #1 Cable Ass'y
7	008-142-12	Mould Cover	1	KR2-7	CR	included in ITEM #1 Cable Ass'y
8	143-085-21	Pan Screw (w/Spring Washer)	1	M4x6	SWRM	
9	009-122-19	Terminal	1	R-3.5-4	CU	included in ITEM #1 Cable Ass'y
10	009-275-18	Compression type Terminal	3	TGNB-5.5(Insulated)	CU	included in ITEM #1 Cable Ass'y
11	072-102-48	Eye Bolt	2	M12	SS	can substitute 072-102-22 (SUS304)
	142-397-13	Washer		d13xd24x0.1t	SUS304	
	142-398-14	Washer		d13xd24x0.3t	SUS304	
12	140-078-19	Hex.Bolt	4	M10x35	SUS304	
13	142-164-19	Spring Washer	4	M10	SUS304	
14	050-000-78	Motor Bracket	1		FC	
15	122-151-11	O-Ring	1	G-200(199.3xd5.7)	NBR	*
16	142-000-07	Wave Washer	1	6305(d61xd51x4.5t)	SK5	
17	052-000-21	Bearing (w/O-ring)	1	AC-6305ZZC3		
18	058-184-11	Lead Wire Protection Plate	1	d90xd224x1.6t	SPHC	
19	143-126-12	Pan Screw (w/Spring Washer/Plain Washer)	2	M4x12	SWRM	
20	053-498-16	Motor Protector 208/230V-60HZ(USA)	1	KA314-HLXL203	(B.C)	
	053-513-18	Motor Protector 460V-60HZ(USA)	1	KA314-HMXL00	(H.C)	
	053-454-23	Motor Protector 575V-60HZ(USA)	1			
21	055-000-67	Rotor	1Set			
22	147-067-16	Impeller Key	1	10x8x32L	SUS420	
23	056-C11-12	Stator 208/230V-60HZ(USA)	1Set			
	056-C12-13	Stator 460V-60HZ(USA)	1Set			
	056-C15-16	Stator 575V-60HZ(USA)	1Set			
24	064-000-11	Motor Frame	1		FC	
25	140-079-10	Hex.Bolt	4	M10x40	SUS304	
26	142-164-19	Spring Washer	4	M10	SUS304	
27	122-151-11	O-Ring	1	G-200(199.3xd5.7)	NBR	*
28	140-032-37	Hex.Bolt	3	M6x15	SWRM	
29	062-223-16	Bearing Fixing Plate	1	d92xd130x4.5t	SS	
30	052-112-10	Bearing	1	6309ZZC3		
31	146-027-11	Retaining Ring	1	C45	SK5	
32	140-104-15	Hex.Bolt	4	M12x65	SUS304	

PARTS LIST		SEWAGE & WASTEWATER PUMPS			10/24/2017	
ITEM	PART No.	DESCRIPTION	QTY	SIZE	MATERIAL	NOTES
33	142-165-10	Spring Washer	4	M12	SUS304	
34	060-429-18	Bearing Housing	1		FC	
35	121-247-12	Packing	2	d12.3xd18x2t	PE	*
36	035-113-18	Oil Plug	2	M12x14	SUS304	
37	140-099-16	Hex.Bolt	2	M12x40	SUS304	
38	142-165-10	Spring Washer	2	M12	SUS304	
39	025-195-13	Mechanical Seal	1	H-35	SiC	
40	143-070-23	Pan Screw	2	M5x6	SWRM	
41	030-156-18	Oil Lifter	1	H-35(A)(T)	Resin	
42	143-070-10	Pan Screw	3	M5x6	SWRM	
43	030-150-12	Seal Stopper	1	H-35(A)(T)	SPCC	
44	122-159-19	O-Ring	1	G-280(279.3xd5.7)	NBR	*
45	029-187-14	Oil Casing	1	100-5.5/7.5-4B2	FC	
46	122-159-19	O-Ring	1	G-280(279.3xd5.7)	NBR	*
47	026-115-12	Oil Seal	1	TC-608212	NBR	
48	021-804-10	Impeller (60Hz)	1	100B45.5-64	FC	
49	144-530-16	Hex.Socket Set Screw	2	M6x15	SUS304	
50	142-202-10	Impeller Fixing Washer	1	d13xd50x15t	SUS304	
51	142-000-22	Spring Washer	1	M12(CP)	SUS304	
52	140-304-17	Hex.Socket Cap Bolt	1	M12x45	SUS304	
53	046-107-13	Air Release Valve	1	PT-1/2	Nylon	
54	020-531-23	Pump Casing	1	100-5.5/7.5-4B2	FC	
55	120-102-11	Packing (S.Cover)		d301xd328x0.3t	PE	
56	022-521-13	Suction Cover	1	100-5.5/7.5-4B2	FC	
57	142-165-10	Spring Washer	3	M12	SUS304	
58	140-097-14	Hex.Bolt	3	M12x30	SUS304	
	173-001-21	Packing O-Ring Set	1Set	(Marked by *)		
15	122-151-11	O-Ring (M.Bracket/M.Frame)	1	G-200(199.3xd5.7)	NBR	*
27	122-151-11	O-Ring (M.Frame/Brg.Housing)	1	G-200(199.3xd5.7)	NBR	*
35	121-247-12	Packing (Oil Plug)	2	d12.3xd18x2t	PE	*
44	122-159-19	O-Ring (Brg.Housing/O.Casing)	1	G-280(279.3xd5.7)	NBR	*
46	122-159-19	O-Ring (O.Casing/P.Casing)	1	G-280(279.3xd5.7)	NBR	*
		Lubricant		Turbine Oil VG32 4,300ml		
	183-013-19	Impeller Puller	1	BE No.13 2"	SGPSS	

PARTS LIST		SEWAGE & WASTEWATER PUMPS				10/24/2017
ITEM	PART No.	DESCRIPTION	QTY	SIZE	MATERIAL	NOTES

EXPLODED VIEW

100B45.5-64

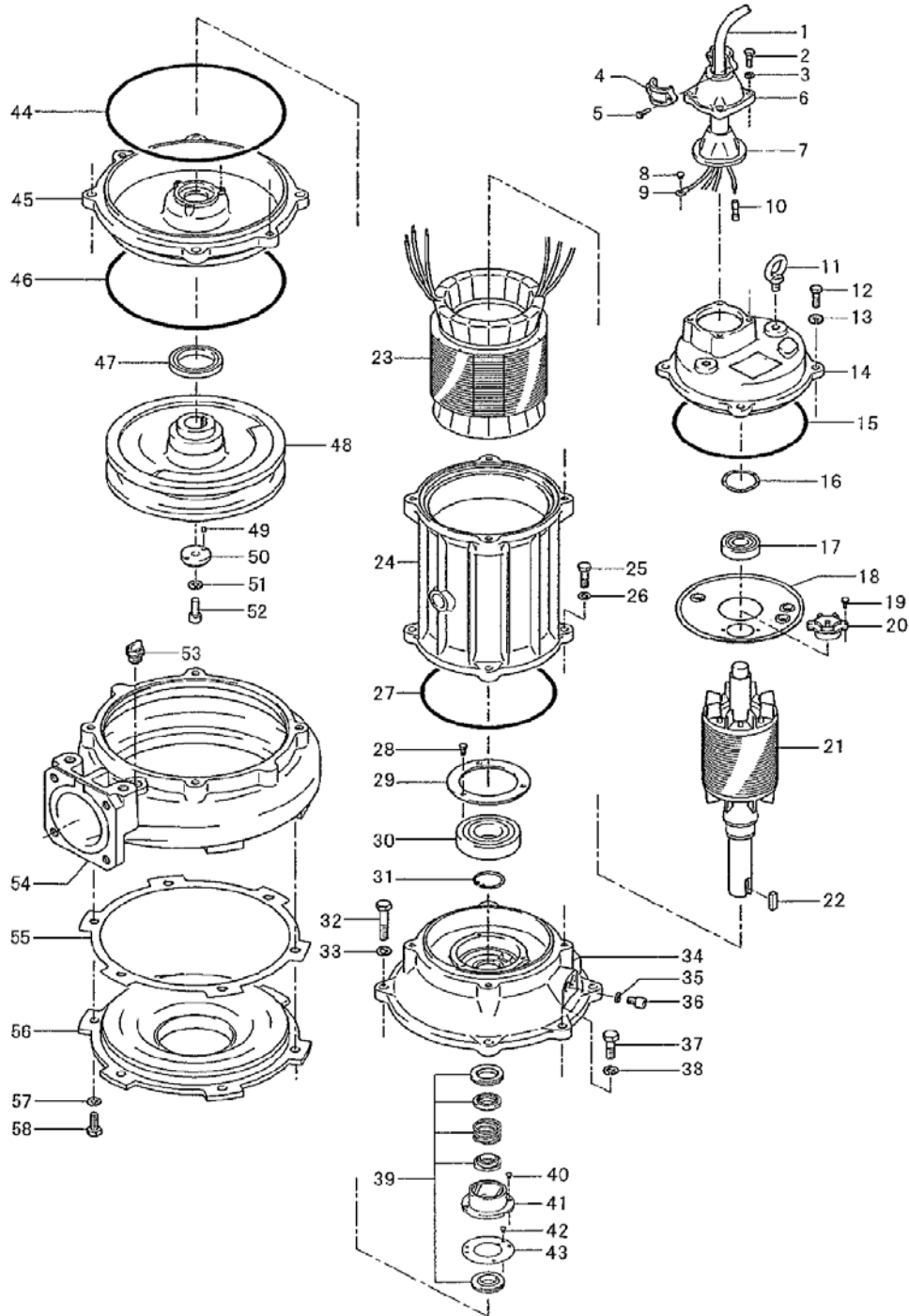

C-01215-2